

Technical Guide



SMARTLARDER

Release date:

July 2023

Please Note: The information shown in this literature is accurate as at the date of release shown but may be subject to changes after such date. Please therefore ensure that you are viewing the most current product available and check with us if you have any doubt about the suitability of the product or accuracy of the information shown.

PACK CONTENTS



1 x Shallow boxed drawer - 83mm

- 1 Drawer runners (L/R)
- 2 Drawer sides and cover caps (L/R)
- 3 Metal back
- 4 Chipboard base
- 5 Internal brackets (L/R)
- 6 Fascia panel (1100mm lengths, cut to required length)*

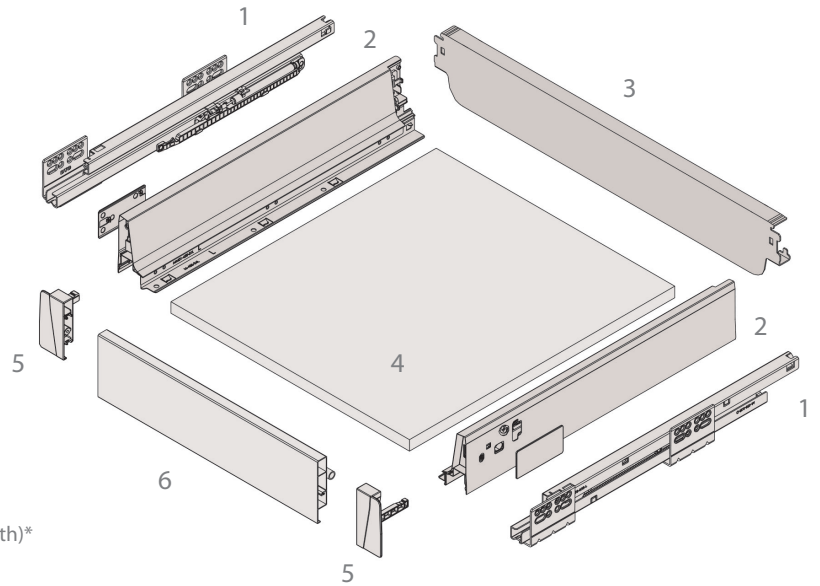

4 x Boxed pan drawers - 224mm

- 1 Drawer runners (L/R)
- 2 Drawer sides and cover caps (L/R)
- 3 Metal back
- 4 Chipboard base
- 5 Internal brackets (L/R)
- 6 Glass sides (L/R)
- 7 Front adapters for glass (L/R)
- 8 Rear adapters for glass (L/R)
- 9 Fascia panel (1100mm lengths, cut to required length)*
- 10 Front square rails (1100mm lengths, cut to required length)**
- 11 Side rails (L/R) (Discard any unused rails)

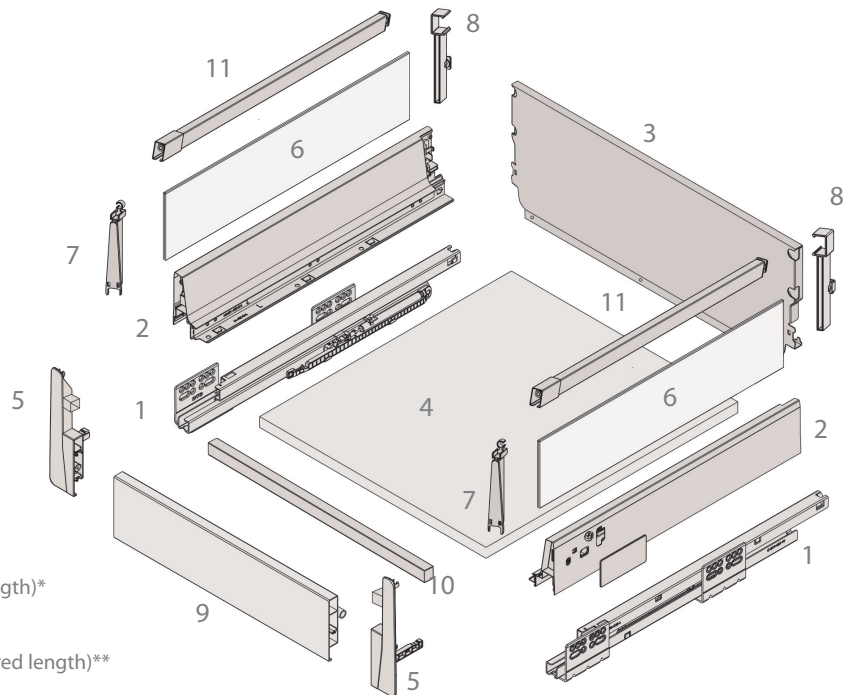

* Fascia panel cutting dimensions:
Internal cabinet width - 97mm
500mm SmartLarder: Cut panel to 367mm
600mm SmartLarder: Cut panel to 467mm

** Front square rail cutting dimensions:
Internal cabinet width - 63mm
500mm SmartLarder: Cut rail to 401mm
600mm SmartLarder: Cut rail to 501mm

NB. You will receive extra parts within your pack. Only the components pictured will be needed to construct your SMARTLARDER. Any extras can either be discarded or kept as spare parts.

PACK CONTENTS



4 x 165 degree soft close hinges
(drilling required on carcass, see **Page 6** for dimensions)

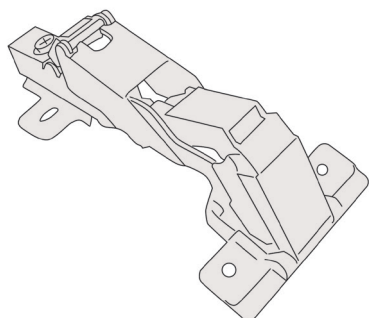

4 x Euro hinge plates 18mm
(drilling required on carcass, see **Page 6** for dimensions)

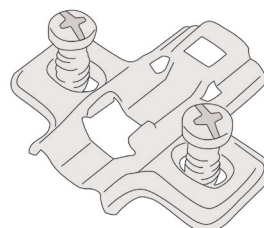

1 x Larder Unit, 1970mm high

- 1 Top panel
- 2 Fixed shelf
- 3 Bottom panel
- 4 Side panels
- 5 8mm back panel
- 6 150mm adjustable feet

Cam & dowel already pre-inserted with simple screwdriver fixings.

Push panels in position and lock in place with a screwdriver.

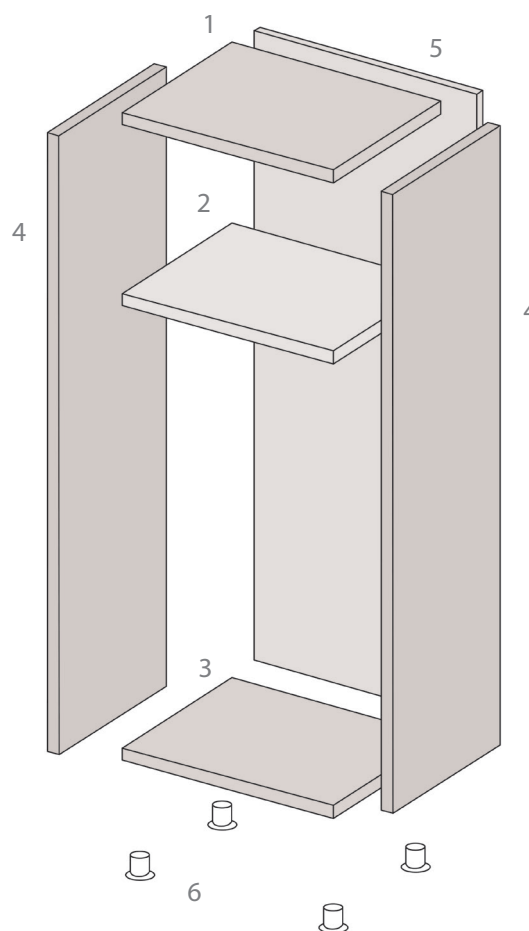

ASSEMBLY



Shallow drawer assembly

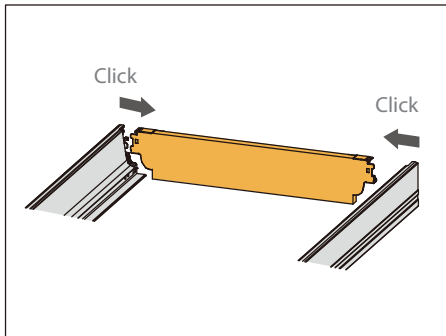

Back assembly

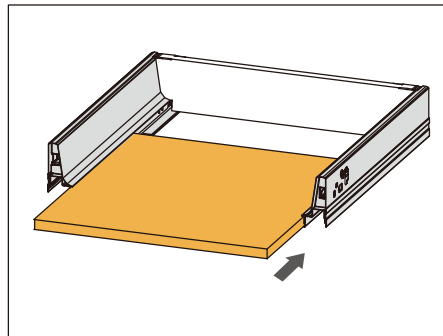

Base assembly

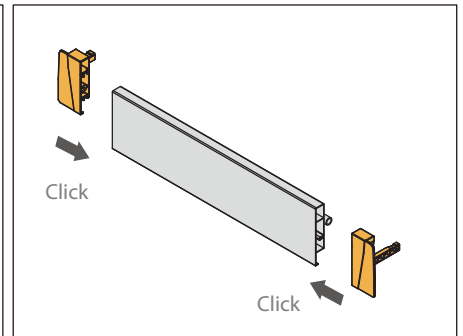

Front assembly

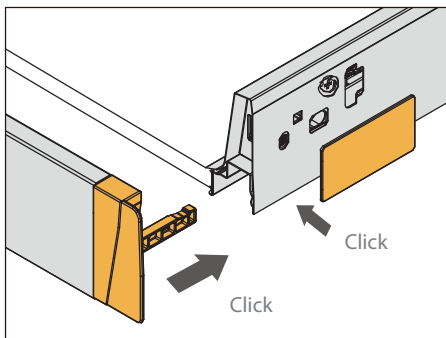

Front assembly (continued)

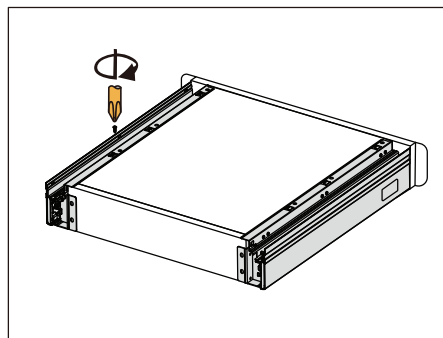

Pan drawer assembly

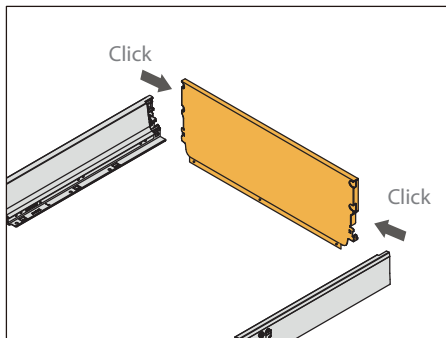

Back assembly

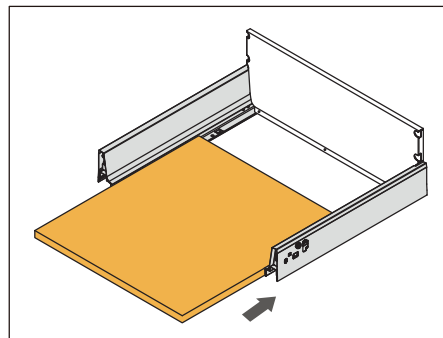

Base assembly

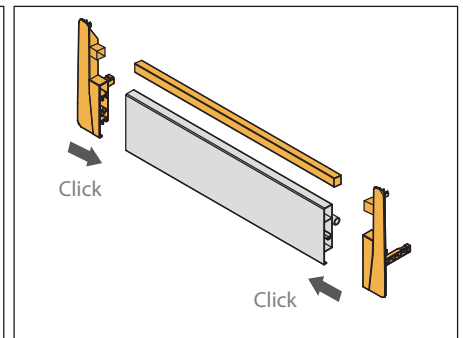

Front assembly

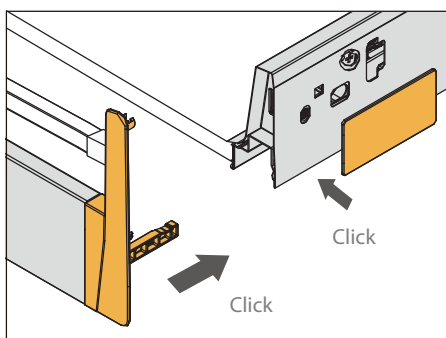

Front assembly (continued)

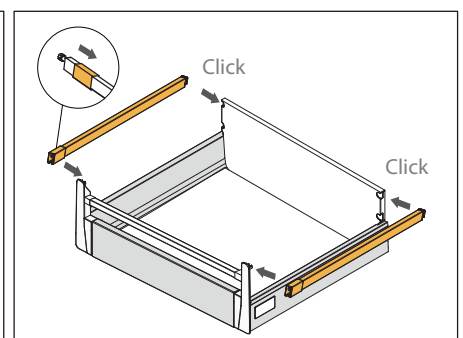
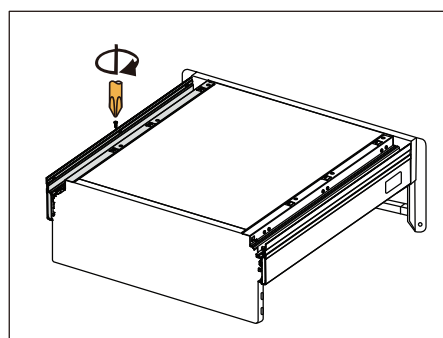

Side rails assembly

ASSEMBLY



Pan drawer assembly (continued)

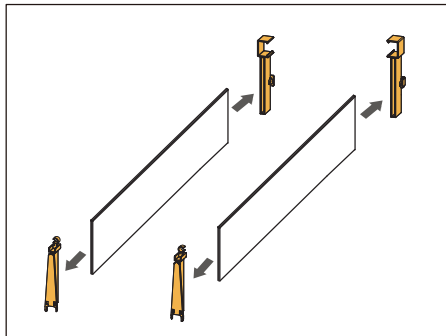

Glass sides assembly

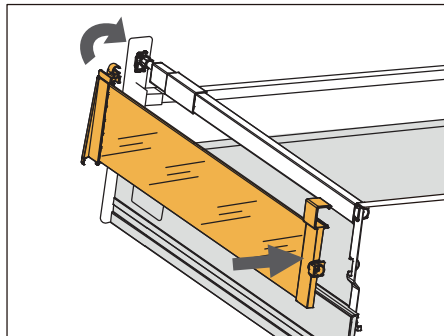

Glass sides assembly (continued)

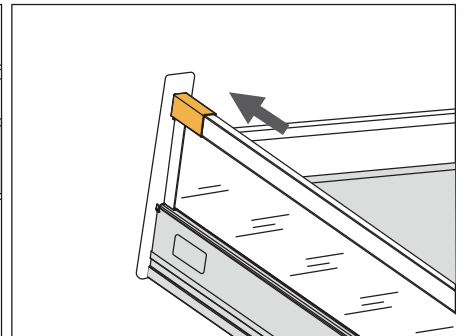

Larder Unit Assembly

View our cabinet assembly video here:

<https://youtu.be/f2RiBnhusRI>



INSTALLATION



All measurements taken from hole centre. Dimensions taken from base, using a 1970mm tall carcass.

Hinge hole positions

Suitable for full height doors or 1245 + 715mm doors. If using 2 doors they MUST be strapped together.

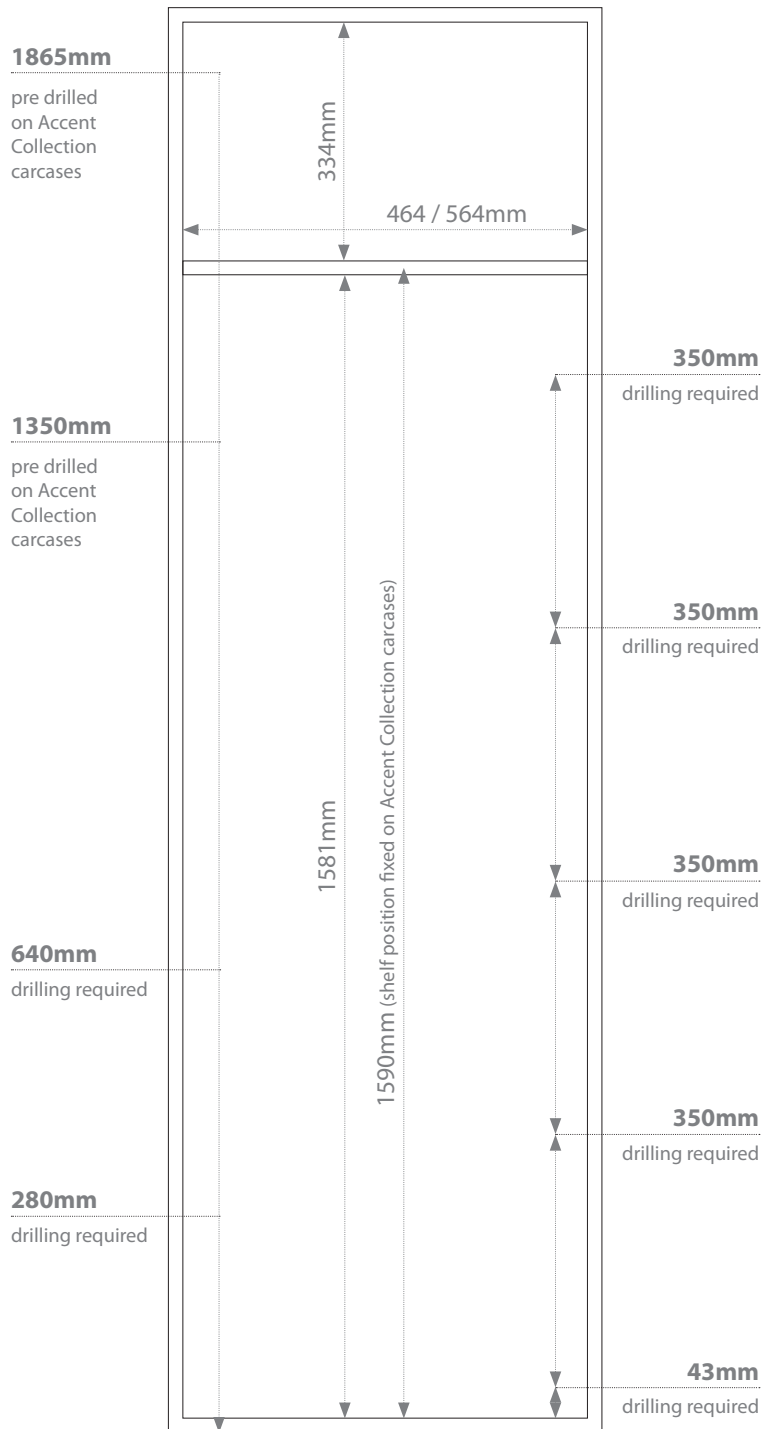

Drawer runner positions

Runner positioning

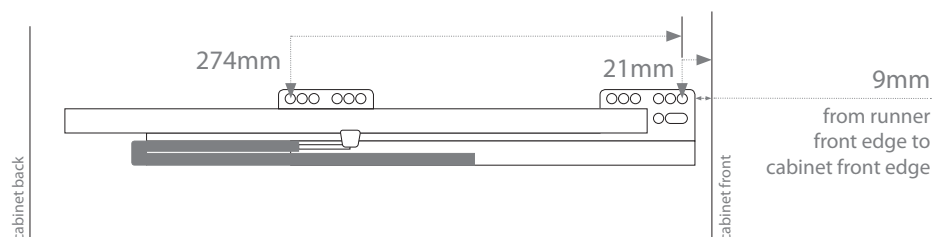

Nb: Please ensure that runners and soft close unit are kept clean and free from dust. When installing units, please cover runners to avoid particles entering the mechanism.